

# MS1



## Product Description:

The MS1 is part of the M series. This compact unit is equipped with a bright 150 Watt LED. With versatile uses, this unit features two prisms, a 3-segment animation effect, 6 bi-rotational gobos, mechanical focus, and 7 colors + aperture that allow you to create colorful effects.

Powerful stepper motors allow the unit to create fast and slow movements in as little as 1.8 seconds for a full 540° pan, and 0.9 seconds for a full 270° tilt.

The MS1 can be used in numerous applications, such as churches, theaters, mobile DJs, and nightclubs, adding attractive multicolor effects.

## 3 Phase Motors

The three-phase motors of the MS1 allow smooth movement, 1.8 seconds for full rotation and 0.9 seconds for full tilt.

## Unique Effects

Features 4- and 6-facet circular overlay prism, 3-segment animation effects, and 6 bi-rotational gobos to create unique aerial effects.

## Very Bright

It is equipped with 150 Watts LED power which can produce a bright powerful projection.

## Mechanical Specifications

---

Pan:	540° 8/16 BIT 3 motors per phase.
Tilt:	270° 8/16 BIT 3 motors per phase.
Shutter:	Electronic shutter
Strobe:	20 flashes/second
Prism 1:	6 overlapping circular faceted prisms
Prism 2:	4 Overlapping circular faceted prisms
Animation Effect:	3 segment animation effects
Gobo Rotation:	6 non-removable bi-rotational gobos
Focus:	Mechanical focus
Color:	7 colors (+aperture)
Tilt and Rotation Lock:	Yes
Focus:	Mechanical Focus
Mounting system:	2 Bi-directional quick release clamps
Electrical Connection:	Powercon type input and output
Signal Connectors:	5 and 3 pin input and output connectors.

## Electrical Specifications

---

Light Source:	1 x 10W LED
Power Supply:	100V-240 50/60 Hz
Power Consumption:	236 Watts / 2.97 Amps

## Control Specifications

---

Display:	LCD display
Protocol:	DMX 512
DMX Channels:	2 modes of operation Mode 1: 17 channel mode Mode 2: 21 channel mode
Control Options:	Individual Pixel Control, RDM

## Size and Weight

---

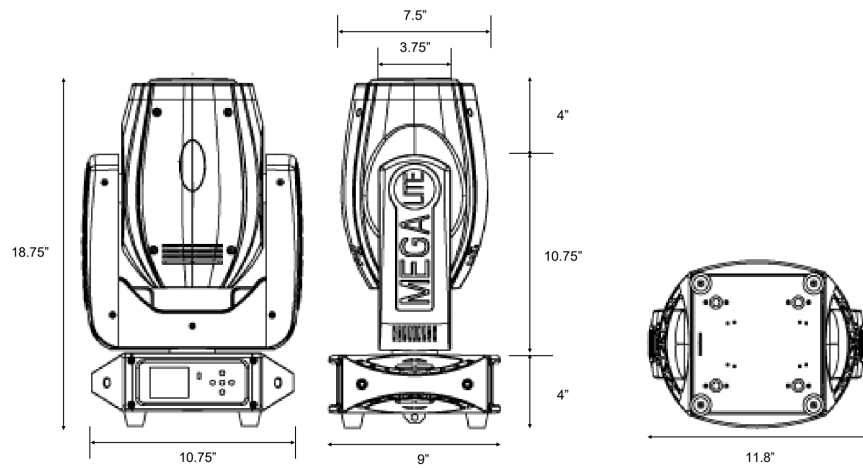

Fixture Size:  
 Fixture Weight:  
 Packaged Size:  
 Packaged Weight:

11.8" x 9" x 18.75"  
 24.5lb (11.11 kg)  
 14" x 12.5" x 23"  
 26lb (11.79 kg)

## Photometrics

Output @ 10ft 8°:

## Included Items

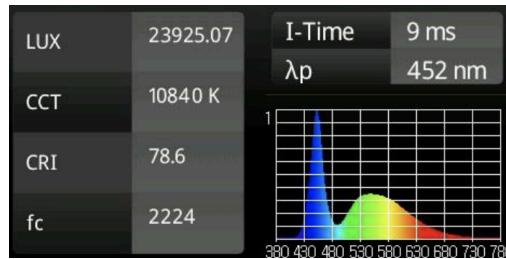

MW1:

1210

## Accessories:

4-Unit Road Case:

CAS-1210-4

## Customer Service

---

MEGA-Lite has a customer support line to provide set-up help and answer any questions should you encounter a problem. Please visit our website for any other related technical documents. For service-related issues, please contact our service department.

Operating Hours:	Monday - Friday 9 AM - 6 PM CST
Phone:	(210) 684-2600
Email:	Service@mega.lighting



**MEGA-LITE**

18662 Bandera RD

Helotes, TX 78023

Phone (210)684-2600 / Fax (210)855-6279

[www.mega.lighting](http://www.mega.lighting) / [info@mega.lighting](mailto:info@mega.lighting)