

MEGA[®]LITE

DRAMA WL 3200



Table of Contents

Safety Information.....	3
Specifications.....	4
Main Power Connection.....	5
Control.....	5
Rigging the fixture.....	6
Cleaning & Maintenance.....	6
Parts List.....	6
Warranty Agreement.....	7

USER MANUAL

Check that the unit has not been damaged during transport



Read all cautions and warnings
prior to operation of this equipment

Protection Against Fire



1. Maintain a minimum of 1 foot distance from any type of flame.
2. Replace fuse only with the specified type and rating.
3. Do Not install the unit too close to a heat source.
4. Make sure cables are properly secured.
5. Maximum surface operating temperature 80°.
6. Do not leave fixture on for long periods of time.

Protection Against Electrical Fire

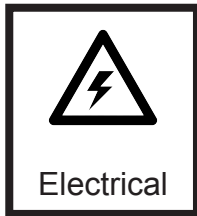

1. Disconnect power before servicing.
2. For connection to main power supply proceed to page 5.
3. This unit must be earthed. (Electrically grounded)
4. Do not expose unit to rain or moisture.

Protection Against Mechanical Hazards

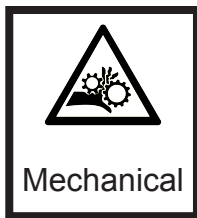

1. Use safety chain when hanging unit.
2. Use quality clamps or bolts when positioning unit
3. Do not open unit while it is on, risk of electrical shock.

Technical Information

Part Numbers

Fixture

7066-Drama WL3200

Mechanical Specifications

Power Connections: Power Con type in & out

Thermal: Maximum ambient temperature 100°F
Maximum surface temperature 130° F

Fastening System: Single Mounting Yoke

Lens Angle: 105°

Barn Doors: Included

Electrical Specifications

LED Quantity: 324 White SMD LEDs

CCT: 3322K

Power Input Voltage: 110V-240 50/60 Hz

Ballast: Electronic Auto Switching

LED Lifetime: 60,000 to 100,000 hours (Average)

Power Consumption: Watts: 100W
Amps: .85 A

LED Watts: .30

LED Scan rate: 7000 Hz

CRI: 91

Lumens: (@full) 9700

Efficacy: 98lm/w

Fuse: 5x20 F5AL250V

Size and Weight

Fixture	6 Unit ATA Road Case
Size: 13.66" x 4" x 7.12"	Size: 30.5" x 23" x 20.66"
Weight: 6.5 lb	Weight: 60.5 lb (empty)

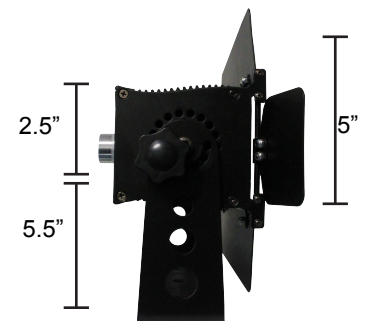



Main Power Connection

Caution!

1. Do not connect fixture to a dimmer system.
2. This unit has Auto switching power supply. It will respond to 100V or 220V automatically.
3. This unit must be earthed. (electronically grounded)
4. Replace fuse only with the specified type and rating.
5. Maximum power Link 15 at 110V and 31 at 220V.

The occupation of the connection-cable is as follows:

This fixture is equipped with an electronic power supply that will let the unit operate from from 100V to 220V from 50 Hz to 60Hz.

Cable (USA)	Cable (EU)	Pin	110V	220V
Black	Brown	Live	L	L
White	Light Blue	Neutral	N	L
Green	Yellow/Green	Ground		

Control

Intensity Control: Intensity Control can be selected by rotating the knob to clockwise for the desired setting. There is 3 levels of intensity.



Rigging the fixture

Caution!

1. The installations must be carried out by an authorized dealer or trained professional.
2. Unit may cause severe injuries if you have doubts concerning the safety do not install.
3. Unit is to be 24 inches away from flammable materials. (Decoration material)
4. Use high quality installation equipment to hang unit.

When rigging a unit it is very important that you follow common safety procedures. Rigging requires extensive experience including but not limited to calculating working loads, material being used and periodic safety inspections. If you lack these qualifications, do not attempt the installation yourself, instead use a professional structural rigger.

When rigging the unit always be secured with a secondary safety attachment. The installation location of the projector has to be built in the way that it can hold 10 times the weight for 1 hour with out any harm to the unit. Installation should be checked at least one time a year by a skilled person.

Cleaning and Maintenance

Installation Maintenance: The operator has to make sure that the unit is operating safely and has the installations and electronics checked by an expert every 2 years.

The following points have to be considered during the inspection:

- 1) All screws used for installing the device or part of the device have to be tightly connected and must not be corroded.
 - 2) There must not be any deformations on the housing, fixation and installation spots (ceiling, suspension, trussing).
 - 3) The electronic power supply cables must not show any damage, material fatigue (e.g. porous cables) or sediments.
- Further instructions depending on the installation spot and usage have to be adhered by a skilled installer and any safety problems have to be removed.

Note: There is no serviceable parts inside the device except for the LED's. Maintenance and service operations are to be carried out by authorized dealers.

Replacing the fuse: When possible, only replace the fuse with the same type and rating.

Replacing the power cable: If the power cable of this device becomes damaged, it has to be replaced by authorized dealers or a trained professional only.

Should you have further questions , please contact your dealer.

Parts List

3010-FAN	REPLACEMENT FAN
7065-PCB-MAI	MAIN PCB CARD
7065-POW	POWER SUPPLY
7065-LED	WHITE LED REPLACEMENT
7065-LED-MOD	WHITE LED MODULE
3010-MUL	MULTIPLE UNIT HANGER
3010-KNO	KNOB SET
3010-RC	6 UNIT ROAD CASE

Warranty Information

GENERAL TERMS AND CONDITIONS

- All resellers must have approved and signed Reseller Application on file including their respective state tax information and W-9. Applications are re-evaluated on a fiscal calendar year basis to assure business integrity and tax status.
- Cash, check, cashiers check, ACH, wire transfer, MasterCard, Visa, Discover and American Express are accepted forms of payment.
- Past due invoices will be charged 1.5% per month finance charge. Uncollected invoices are subject to be turned over to collection.
- The reseller will pay all reasonable expenses incurred in the course of collections.
- The proper venue for litigation will be Bexar County, Texas.
- Returned checks will be charged a \$50.00 fee.
- All prices are in U.S. Dollars.
- All prices and specifications are subject to change without notice, sales order confirmations are emailed and will reflect correct pricing.
- All terms are insured, monitored, analyzed and approved by Coface USA. Changes in credit line and approved terms can change without notice. Company authorization of credit is based on Coface approvals any conflicts or disagreements should be referred to:
650 College Rd East Suite 2005 Princeton, NJ 08540. 1-609-469-0400. E-mail: cofaceusa@coface.com
- Returns are subject to 25% restocking charge plus any necessary charges for repair or re-packaging.

SHIPPING TERMS AND CONDITIONS

- All orders are EXW San Antonio, TX (EXW means that a buyer/reseller incurs the risks for bringing the goods to their final destination) any deviation needs to be done in writing.
- UPS ground shipping is the preferred shipping method. Requests for specific carriers may require use of the customer's account number and may incur an additional charge for handling.
- Drop shipments are subject to all return charges at resellers expense. Drop shipments are not allowed outside of the territorial United States.
- NO C.O.D. shipments allowed.
- Returned and undelivered shipment charges are the buyer/resellers responsibility and will be billed to the buyer/reseller.
- The freight carrier and Company shipping@mega.lighting should be notified upon receipt of damaged freight, discrepancies or non-conformities within 24 hours. Company can assist in making claims with carriers or agents in the event of any loss or damage.
- Upon acceptance in good order by Carrier from Company, the material becomes the property of the Reseller.

WARRANTY AND SERVICE PROCEDURES

- All returns require an RMA# (Return Merchandise Authorization number) before returning goods for any reason. For a service or warranty RMA please email service@mega.lighting or call 210-6842600. For sales or demo returns please contact sales@mega.lighting.
- Case will be created and an RMA notice will be emailed. All units received must have the RMA # included with the unit as well as on the shipping label.
- All shipping charges are the responsibility of the customer: MEGA Systems, Inc., Service, 18668 HWY 16 N, Helotes, TX 78023.

WARRANTY FOR PRODUCTS PURCHASED BEFORE 2021

Unless otherwise stated in writing, product is covered by a **one year parts and labor** limited warranty and is subject to same limitation listed under the limited warranty exclusions listed below.

WARRANTY FOR PRODUCTS PURCHASED AFTER JANUARY 1, 2021

MEGA SYSTEMS INC ("MSI") hereby warrants to the original purchaser/owner ("Customer"), MSI products to be free of manufacturing defects in material and workmanship, for the warranty periods as defined below from the original purchase invoice date. This warranty applies exclusively to new MSI branded and/or distributed products listed below, purchased from an MSI AUTHORIZED dealer/reseller. This warranty is not transferable and may or may not apply to products sold and/or forwarded outside the United States. Please contact MSI for applicable regional product warranty information. The purchase of MSI product constitutes the Customer's acceptance of all warranty terms and conditions as listed in this limited warranty statement. This warranty provides the Customer with legal rights, which may vary from state to state. Please contact MSI regarding warranty questions prior to purchasing.

Product / Series	Warranty Period	Coverage
BATTERY POWERED LED	Six month battery one year all other components	1, 2
MOVING LED, HAZERS	One year	2
OUTDOOR IP RATED LED	Two Year	3
HOUSE LIGHT LED, DECORATIVE LED, COMPACT LED, ICANDY LED, THEATRICAL LED, STROBE WASH LED, FOLLOW SPOT LED, PRODUCTION & HOUSE OF WORSHIP CONTROL, ARCHITECTURAL CONTROL, THEATRICAL CONTROL, DANCE VENUE & MOBILE DJ CONTROL, DIRECT VIEW LED DISPLAYS, AND MV CONTROLLERS	Three Year	4
1. Battery, 183 days six months 2. Parts and Labor, 365 days one year 3. Parts and Labor, 730 days two year 4. Parts and Labor, 1095 days three year		
This limited warranty excludes any defects caused by, resulting from or relating to the following:		
Normal wear and tear of lamps, color media, brushes, contact rings, lamp sockets, belts and other parts prone to wear and tear.		
Misuse, abuse, improper handling, accident, alteration or attempts to repair by or on behalf of the owner or any person not authorized by MSI.		
Damage to the product resulting from acts of God, including, but not limited to, earthquakes, hurricanes, tornados, lightning and other natural disasters, fire, explosion, flood, riots, civil disorder or any other cause beyond the reasonable control of MSI.		
Exposure to harsh or excessively corrosive environmental conditions (whether indoors or outdoors), including, but not limited to, extreme temperatures, humidity, atmospheric conditions (including salinity or pressure), radiation (UV, infrared or nuclear), shock and conditions which exceed the product's Ingress Protection ("IP") rating.		
Use of the product in a manner which exceeds the applicable product specification, including, but not limited to, exposure to excessive, insufficient or other voltage conditions.		
Installation or use of the product not in accordance with the technical documentation, MSI guidelines (as may be posted on its website at www.megasystemsinc.com from time to time or otherwise designated by MSI or its brands) or applicable building and electrical codes, regulations and standards.		
Failure to maintain the product in accordance with the technical documentation.		
Natural degradation and color shift of the LED source over the course of normal product use.		
Slight deviations in the specified values of intensity and color that do not affect the functionality of the product.		
Use of the product not for its intended purpose.		

All warranty claims are evaluated under the terms of this limited warranty. If a product falls within the warranty period and if, upon examination by MSI it is found to have failed for a covered cause, MSI will, at its sole discretion, repair or replace the defective part or product or reimburse the purchaser a pro-rated portion of the purchase price based on the percentage of the warranty period still remaining as of the date that the returned product was received by MSI. Should a replacement part or product be discontinued or unavailable, MSI reserves the right, in its sole and absolute discretion, to substitute a comparable replacement part or product for the defective part or product. MSI warranty obligation hereunder is limited solely to the repair or replacement of or reimbursement for the particular parts or products determined by MSI to have failed for a covered cause within the warranty period. In no event shall MSI be responsible to replace or reimburse purchaser for any products or portions of a system that MSI determines has not failed for a covered cause within the warranty period, even if such other products or portions of a system are used together with products being repaired or replaced by MSI under this warranty and the repaired product differs in brightness, colors or any other attribute after the repair.

Costs of removal, shipping to MSI or its authorized representative and reinstallation are solely the responsibility of the purchaser. If MSI determines that the product is covered by this limited warranty, it will only pay for parts and labor as indicated by product type. If MSI determines that the product is not covered by this limited warranty, the purchaser will have the option of paying for the repair (if the product can be repaired) and the purchaser shall be responsible for the cost of shipping the repaired product back to the purchaser. MSI reserves the right, in its sole and absolute discretion, to decline any repair.

IN NO EVENT SHALL MEGA SYSTEMS, INC. BE LIABLE FOR ANY INCIDENTAL, CONSEQUENTIAL, SPECIAL, INDIRECT OR PUNITIVE LOSS OR DAMAGE OF ANY KIND, INCLUDING, BUT NOT LIMITED TO, LOSS OF PROFITS OR REVENUES, LOSS OF USE OF THE PRODUCT OR ANY OTHER GOODS OR ASSOCIATED EQUIPMENT, DAMAGE TO ANY ASSOCIATED EQUIPMENT, COST OF CAPITAL, COST OF SUBSTITUTE PRODUCTS, FACILITIES OR SERVICES, DOWN TIME COST, INSTALLATION OR LABOR COSTS, OR CLAIMS OF THE PURCHASER'S CUSTOMERS, WHETHER BASED ON WARRANTY, CONTRACT OR NEGLIGENCE, ARISING IN CONNECTION WITH THE SALE, USE OR REPAIR OF THE PRODUCT. MEGA SYSTEMS INC'S MAXIMUM LIABILITY SHALL NOT, IN ANY CASE, EXCEED THE PURCHASE PRICE OF THE PRODUCT THAT GIVES RISE TO THE CLAIM.

EXCEPT FOR THE LIMITED WARRANTY SET FORTH HEREIN, ALL PRODUCTS SOLD BY MEGA SYSTEMS, INC. ARE SOLD "AS IS" WITHOUT ANY WARRANTY, EXPRESS OR IMPLIED, STATUTORY OR OTHERWISE, INCLUDING, BUT NOT LIMITED TO, IMPLIED WARRANTIES OF MERCHANTABILITY AND FITNESS FOR A PARTICULAR PURPOSE, ALL OF WHICH ARE EXPRESSLY AND SPECIFICALLY DISCLAIMED BY MEGA SYSTEMS, INC.

Customer Support

Mega Lite has a customer support line to provide set up help and to answer any questions should you encounter a problem. Please visit our website for any other related technical documents. For service related issue please contact our service department.

Monday—Friday 9am to 6pm CST
Telephone: 210-684-2600
E-mail: service@mega.lighting

Manual Version

Please Visit www.mega.lighting for the most up to date manual version.

Document Version	Date	Fixture Software	Notes
1.2	03/24/2021	V1.1	

MEGA LITE[®]

Mega-Lite
18668 Highway 16N
Helotes, Texas 78023
Ph 210-684-2600 Fax 210-855-6279
www.mega.lighting / info@mega.lighting